



IBS C12 CASE SEALER



"A modular model which can be adapted with Tape or Hot-Melt or both"

LUNDGREN MACHINERY
– for an everyday smooth production –

IBS C12

”A modular model which can be adapted with Tape or Hot-Melt or both”

Flexible and easy to handle:

The machine is of a solid design in stainless steel, automatic folds and seals corrugated board cases with tape and or Hot-melt. It can be supplied with either right- or left hand discharge direction. It is also ergonomic, easily accessible and requires a minimum of floor space. Choices for the model is many, Top-closing with tape or Hot-melt or if needed both. You can also choose a model to close in bottom with tape and the version both top and bottom closing. When to close the box a motor powered driven side belts takes control of the box thru the tape and/or glue station. Nordson ProBlue as standard when Hot-Melt (Robatech optional).

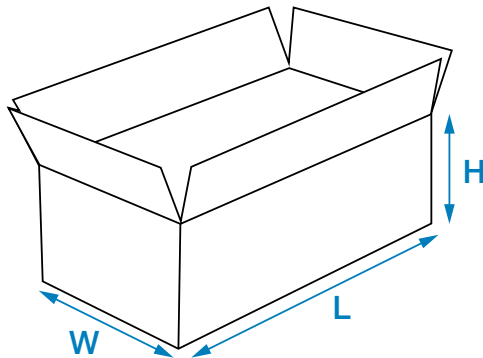

Machine range, case sizes and capacities

Type	Tape/Glue	L (mm)		W (mm)		H (mm)		Cases/Min.
		min	max	min	max	min	max	
C12TT	Tape	200	600	150	400	150	400	20
C12TBT	Tape	200	600	150	400	150	400	20
C12TG	Hot-Melt	200	600	150	400	150	400	20
C12BT+TG	Tape/ Hot-Melt	200	600	150	400	150	400	20

Lundgren Machinery AB manufactures machinery and other appliances primarily for the food-, chemical- and pharma-ceutical sectors. After a hundred years we can, with a good conscience, safely say that we are a reliable partner. With us you can expect cutting edge technology, short lead times, high quality, secure delivery times and not least, a reliable supplier. Find our contact information and more information about us on www.lundgrenmachinery.se. More news and all about us via our App at AppStore and Google play for our latest development's.

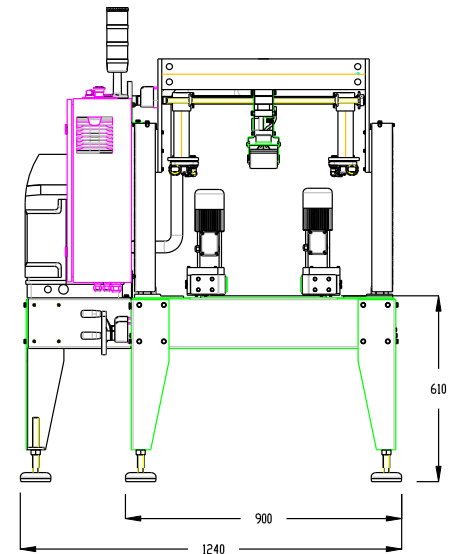
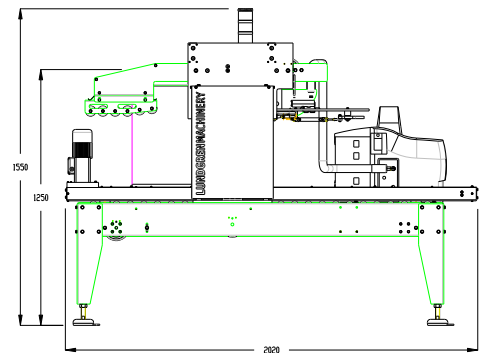

Specifications:

Electrical: 3x400V AC + N + PE, 50 Hz,
Fuse 16 Amps.

Control: Festo.

Drive: Pneumatic Festo

LUNDGREN MACHINERY
- for an everyday smooth production -